

JesLoader®

Reliable accuracy



Advanced weighing and dosing systems for static, dynamic, and continuous weighing.

jesma®
weighing solutions

JesLoader®

The new unique development in truck loading scales.

The Jesma JesLoader is designed for loading a pre-set amount of bulk material into a truck from multiple silos. The JesLoader is mounted on rails so it can be moved from one silo to another, loading the required amount of material from each. The JesLoader eliminates the need for mounting a scale below each silo or the need for repeated trips to a bridge scale after the filling from each silo.

The functionality of the Jesloader:

After the truck has been positioned correctly, the operator enters the target loads into the control system. Jesma delivers a controller especially developed for the JesLoader. The absolute JesLoad HMI controller consists of 2 cabinets. One placed on the JesLoader containing weighing amplifiers, PLC and positioning hardware from Siemens. The second cabinet is an operator cabinet with the SIEMENS touch HMI 9" for operator information, adjustment of parameters, current status and diagnostics.

The JesLoader will position itself correctly below the pre-programmed silo by navigating via encoder and positioning hardware from Siemens.

When the Jesloader is positioned under the silo, the entered amount of product is released into the scale as ordered through the receipt handing system.

After completed filling, the JesLoader is guided into the correct position above the truck inlet. The product will be released into the truck after accept from the operator.

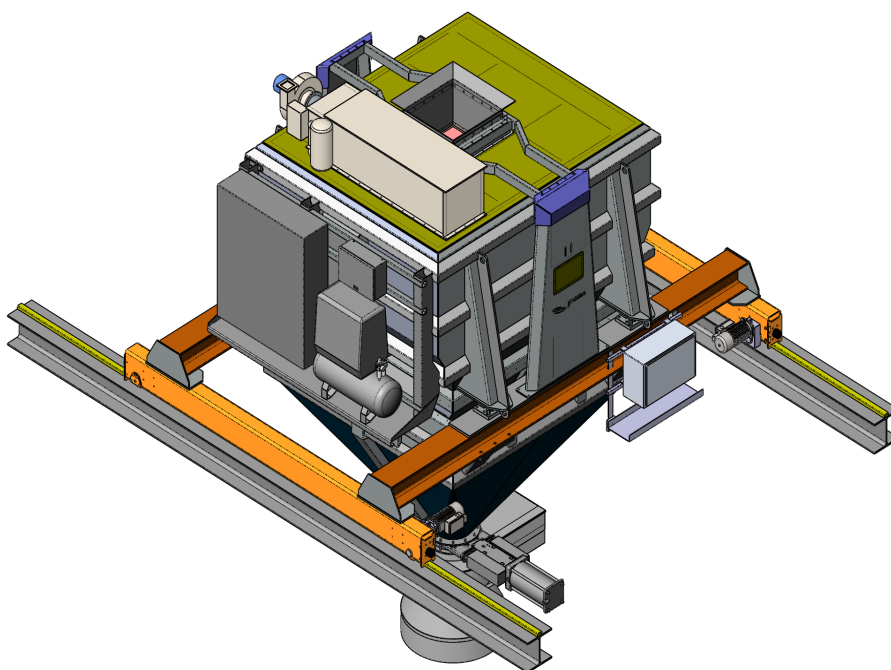



Reliable accuracy

Technical specifications

- The static weighing accuracy is $\pm 0.1\%$.
- Two models with capacity of 8,5 or 12 m³.
- Adjustable inlet +100 mm vertical to ensure dust tight loading from the silos.
- Controlled positioning using Siemens SINAMIC positioning controller to ensure correct placement of the JesLoader.
- Can be designed for connecting different outlet devices for correct truck filling, depending on clients requirement.
- Standard version with guide rails and energy chain for a driving length of 20 m.
- Driving speed up to 25 m/min.
- Closed construction to minimize dust emission to the surroundings.
- Service friendly and easy maintenance.

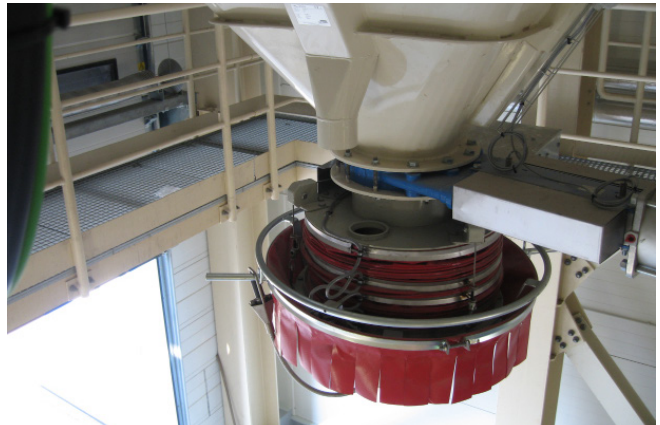



Jesma HQ
Helsingørvej 18
DK-7100 Vejle
+45 75 72 11 00
Jesma@jesma.dk

Jesma Poland
Ul. Firmowa 18
PL-62-023 Robakowo
(+48) 722 011 022
(+48) 61 8 383 787
mtr@jesma.com

Jesma Latam
Zapiola 574, Chacabuco
Buenos Aires, Argentina
+54 9 23 64 41 88 99
dc@jesma.com

 Part of Jesma Group

www.jesma.com