

Jesma Aqua Line

Food industry scales for the wet- and hygienic industries

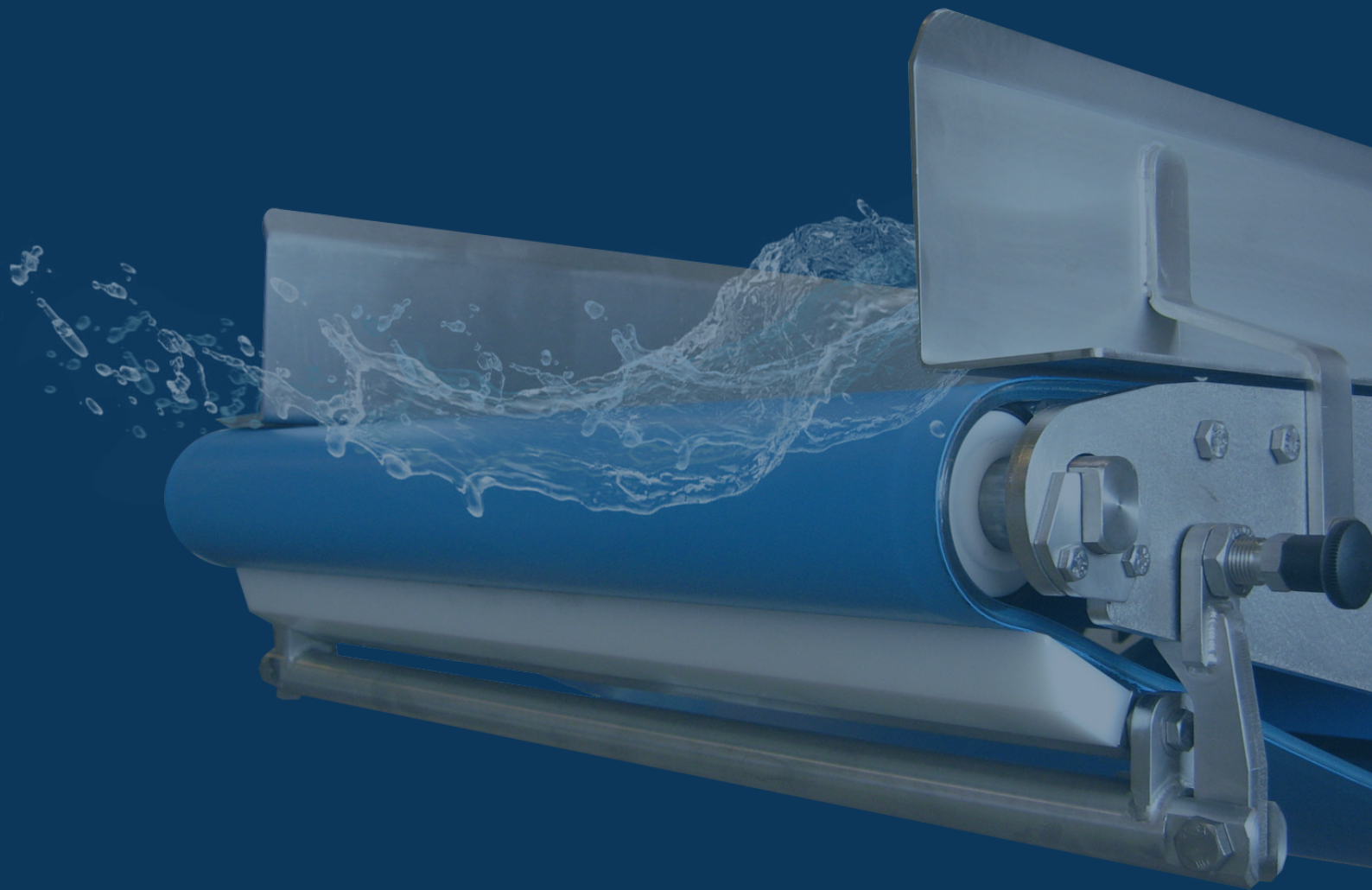

Jesma[®]
weighing solutions



For wet and sticky products

JesBelt® K

The JesBelt K is designed for use in the food processing industry, meaning that the weigher is designed with cleanliness and high accuracy in mind.

Description for the JesBelt K

Compared to traditional weigh feeders the JesBelt K design is considerably simpler. The weighing part is inserted into the construction and by means of a two single point load cells excellent stability and accuracy is achieved.

The JesBelt K is designed for use in the food processing industry, which is thought into the design, the weigher is constructed in modules making it easy to service and easy to clean. In the JesBelt K construction the weighing part is moved from the end of the belt and instead inserted into the actual construction. The belt can be demounted, as well as all rollers can be dismantled and washed, enabling thorough cleaning of the equipment.

With the JesBelt K range, problems with stability and accuracy are minimized as there is no zero-offset due to product deposits.

The weigh feeder can be used in many applications that require a built-in weighing function. With great accuracy, the JesBelt K can work with a wide range of materials such as fish, meat, and vegetables.

Capacity	Up to 90 m ³ /h.
Accuracy	+/- 1% Within 20-100 % of max capacity.
Belt length standard	1800 or 2800 mm
Belt width standard	600 or 800 mm
Speed	To be determined
ATEX Zone	Defined by client



Technical data

JesBelt K in general

- Sturdy industrial execution in stainless AISI 304, pickled and glass blasted.
- Automatic belt tightening (gravimetric).
- Outer scraper on outlet roll, which easily can be opened for cleaning.
- Removable frame construction of belt rollers before, after and on the weighing part for easy cleaning.
- Stainless steel load cell IP67 built into housing.
- FDA-approved belt type E8/H U0/U2 MT HVID FDA.
- Incl. removable side rails and end rail.
- Incl. support frame for mounting of weigher.

Principle sketches

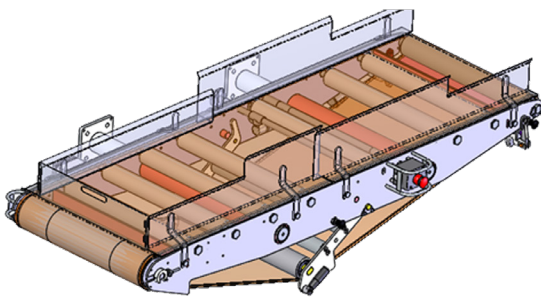

JesBelt K with side- and end rails, excl. support

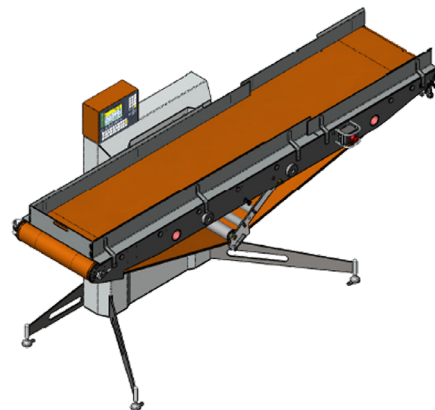

JesBelt K with side- and end rails, incl. support

JesBelt K 600 [up to 45 m³/h ~ 35 t/h, density 0,8]

Belt width (mm)	Belt length (mm)	Weight [kg]	Weight frame [kg]
600	1800	210	150
600	2800	250	175

JesBelt K 800 [up to 90 m³/h ~ 75 t/h, density 0,8]

Belt width (mm)	Belt length (mm)	Weight [kg]	Weight frame [kg]
800	1800	250	200
800	2800	300	225



For the food, wet- and hygienic industries

JesBelt A-FG Flex

The JesBelt A-FG Flex is specially designed for the food industry. Compared to traditional weigh feeders, the design of the JesBelt A-FG Flex has been made in order to ensure easy access to all parts and easy cleaning of the weigh feeder.

Description for the JesBelt A-FG Flex

The JesBelt A-FG Flex is Jesma's first dynamic JesBelt with a flex belt. It is designed and constructed for continuous weighing of a material transported on a belt, or for regulation of a specific material flow. The weigh feeder is built around mechanically isolated weigh bridge with 4 load cells.

The weigher is as standard carried out in AISI304 stainless steel. The JesBelt A-FG Flex is applicable for many applications requiring a built-in weighing function. With great accuracy, the JesBelt A-FG Flex can work with different materials such as fish, meat, and vegetables. With the JesBelt A-FG Flex range of weigh feeders, problems with stability and accuracy are minimized as there is no zero-offset due to product deposits.

Capacity	Up to 100 m ³ /h.
Accuracy	+/- 1%
	Within 20-100 % of max capacity.
Belt length standard	2000 or 3000 mm
Belt width standard	700 or 900 mm
Speed	To be determined
ATEX Zone	Defined by client



Technical data

JesBelt A-FG Flex in general

- Stainless steel modular construction.
- Easy access to all parts and easy cleaning.
- product guide rails.
- Belt is manufactured in FDA approved material.
- The belt is supplied with a solid and robust edge design, incorporating improved pin retention.
- Incl. sprockets with large solid tooth insuring superior load transmissions and long lifetime.
- Shafts for Sprockets are fully closed and not hollow.
- Bearings are special hygienical bearings designed especially for the food industry.
- All bolts are placed on the outside of the construction and can be easily cleaned and inspected.
- All surfaces are visible and can be easily cleaned.
- Electrical components min. IP65.
- ATEX compliant components available.

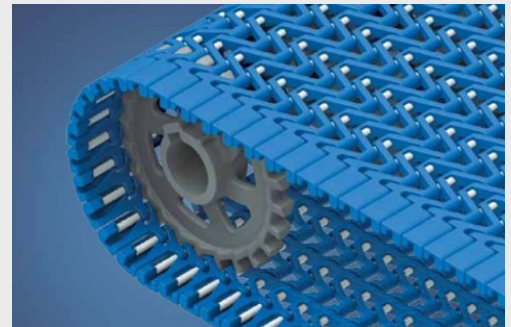

JesBelt A-FG Flex 700

[up to 50 m³/h ~ 40 t/h, density 0,8]

Belt width (mm)	Belt length (mm)
700	2000

JesBelt A-FG Flex 900

[up to 100 m³/h ~ 80 t/h, density 0,8]

Belt width (mm)	Belt length (mm)
900	3000



Food grade approved technical weighing solution

JesBelt® A-FG

Drawing from the experience of hundreds of supplied weigh feeders, the JesBelt A-FG, a food grade approved technical solution, emerges as the ultimate choice within its domain. The JesBelt A-FG is composed of carefully selected components and has a high reliability and an optimal lifespan.

Description for the JesBelt A-FG

With its flexibility, the JesBelt A-FG seamlessly caters to a diverse range of process industries, where precision and linearity are fundamental to achieving an efficient production line. Its construction revolves around an isolated weigh bridge, featuring four load cells and automatic belt tension. This technical design ensures stability, accuracy, and linearity during weigh feeder operations – advantages further enhanced by the compliance of the JesBelt-A FG with EU directives and OIML R50, Welmec, and MID, facilitating its purchase and sales approval.

The JesBelt A-FG is equipped with a high signal rate incremental encoder (Tacho) and a monitoring system. The Tacho is mounted on the idle drum of the conveyor and tracks the belt's speed, promptly alerting operators to even the slightest irregularities in the weigh feeder's operation.

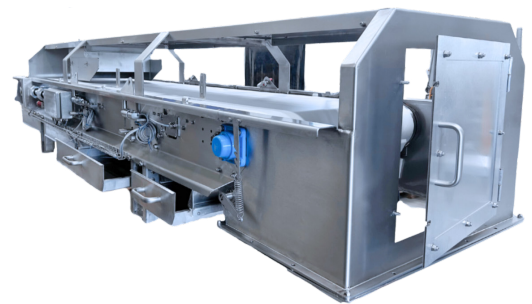

To guarantee precise weighing accuracy, the conveyor belt of the JesBelt A-FG features a plow-shaped scraper on its inner side. This scraper removes any adhesive materials, ensuring they do not influence the weighing accuracy.

Manufactured in stainless steel AISI304, chosen to meet food contact requirements, the JesBelt A-FG is available in a range of standard sizes. All components are carefully selected to ensure compliance with Regulation (EC) No. 1935/2004, which governs materials intended for contact with food. Furthermore, the JesBelt-A FG can be customized as project-designed equipment, offering options that surpass the standard range.

Technical data

JesBelt A-FG in general

- Flexible rim to eliminate product spill or guide rails dependent on product properties.
- Dust cover including outside scraper of the belt, flanged inlet and outlet, and dust extraction connection.
- Dust tray for manual emptying or option with cleaning drawers.
- Option with automatic cleaning bottom.
- Scrapers for adhesive and sticky products.
- Inlet funnel with damper for regulation of product flow.
- Outlet funnel.
- Belt tracking switches.
- Emergency stop with wire.
- ATEX compliant components available.
- Optional metal detector.
- Optional safeguard of product flow by mounting magnets and detectable strips to prevent contamination.

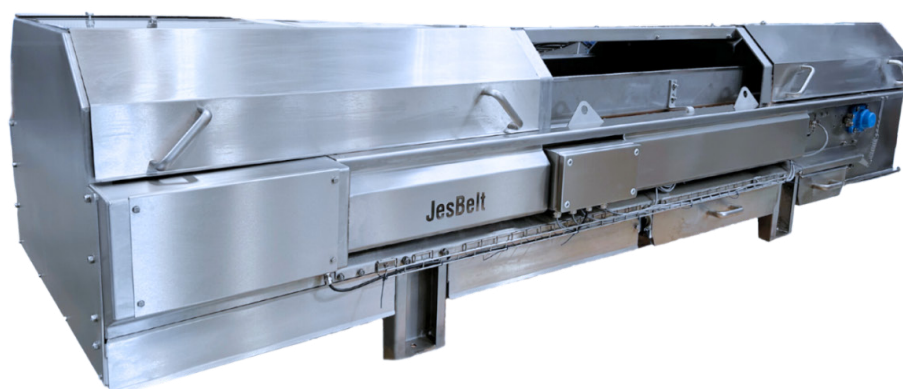

Capacity	450 m ³ /h.
Accuracy	From 0,5% (Subject to final design and product properties).
Belt width	500-1600 mm
Ambient temperature for approved versions	-10°C...+40°C.
ATEX options	Zone 21+22



Jesma Latam
Zapiola 574, Chacabuco
Buenos Aires, Argentina
+54 9 23 64 41 88 99
dc@jesma.com

Jesma HQ
Helsingørvej 18
DK-7100 Vejle
+45 75 72 11 00
Jesma@jesma.dk

Jesma Poland
Ul. Firmowa 18
PL-62-023 Robakowo
(+48) 722 011 022
(+48) 61 8 383 787
mtr@jesma.com

 Part of Jesma Group

www.jesma.com